

NOTE: MAY BE LABELED
WHEN PROPERLY WELDED

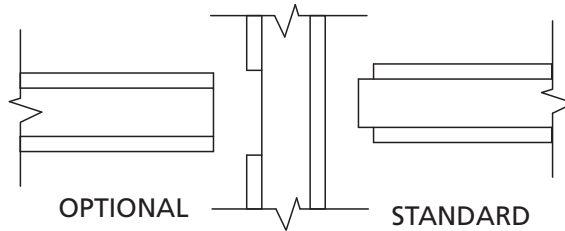

Drywall KD "CG" Profile Corner Details

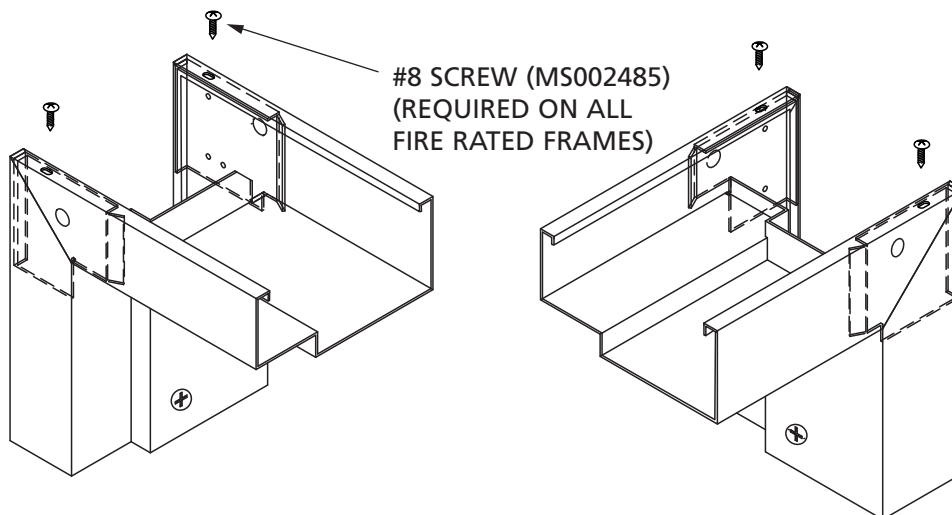



C PROFILE CORNER

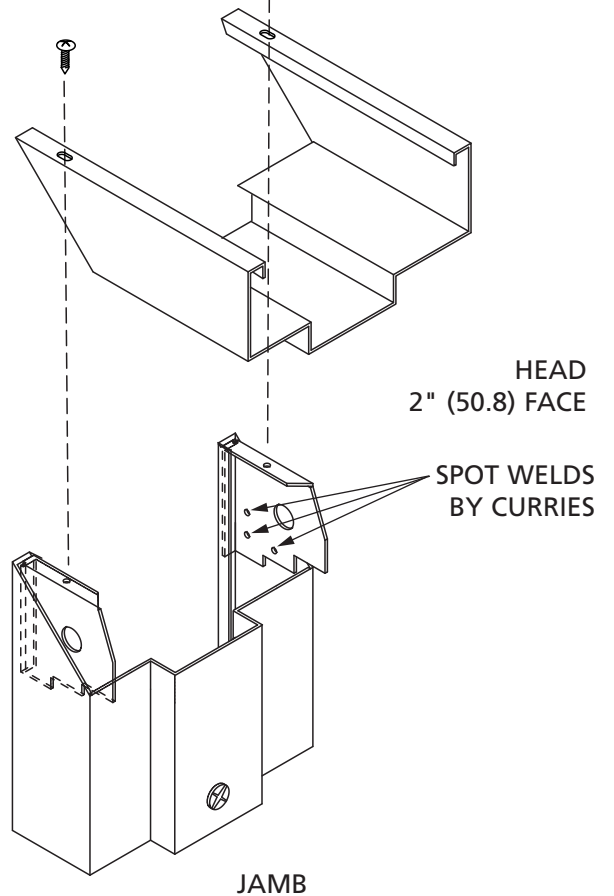
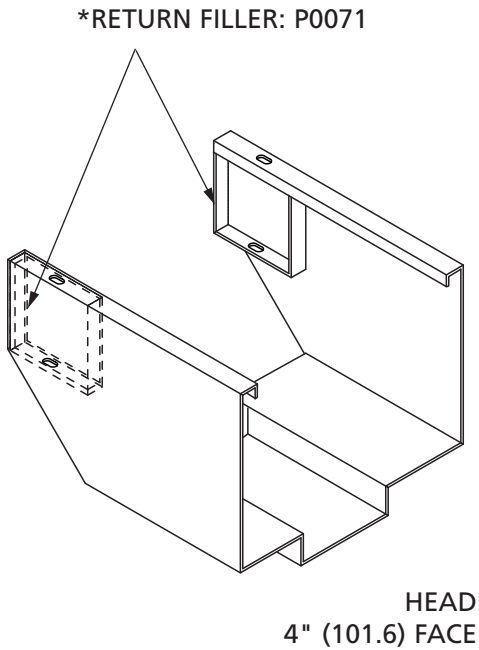
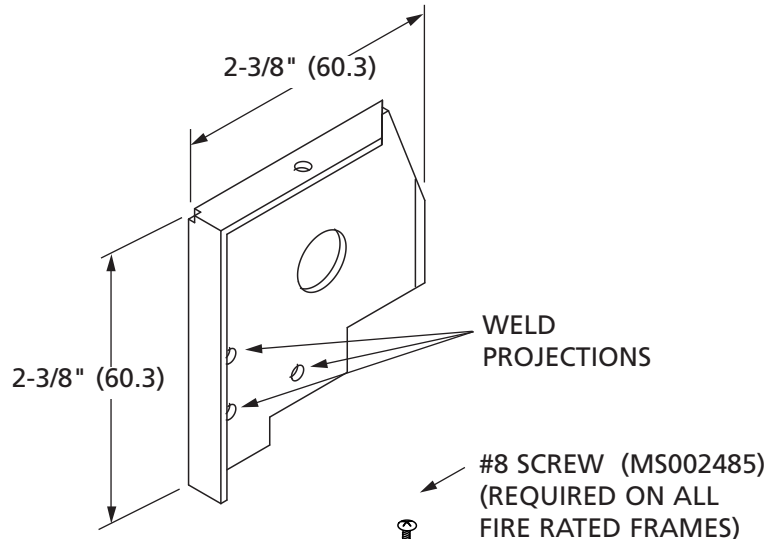
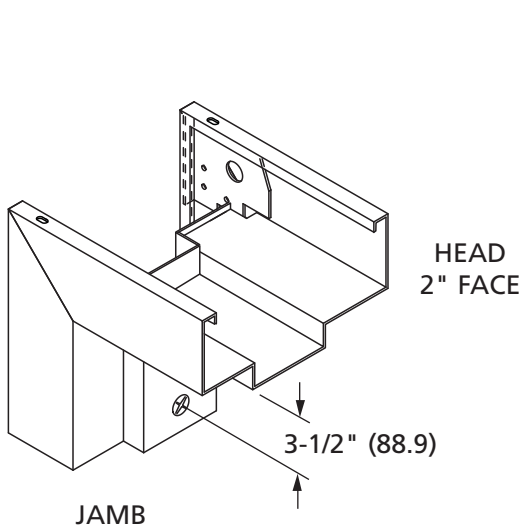

34 Security Anchor

FRAME TECHNICAL DATA

April 1, 2002



ASSA ABLOY

ASSA ABLOY, the global leader in door opening solutions



ANCHOR PART NUMBER: P0028

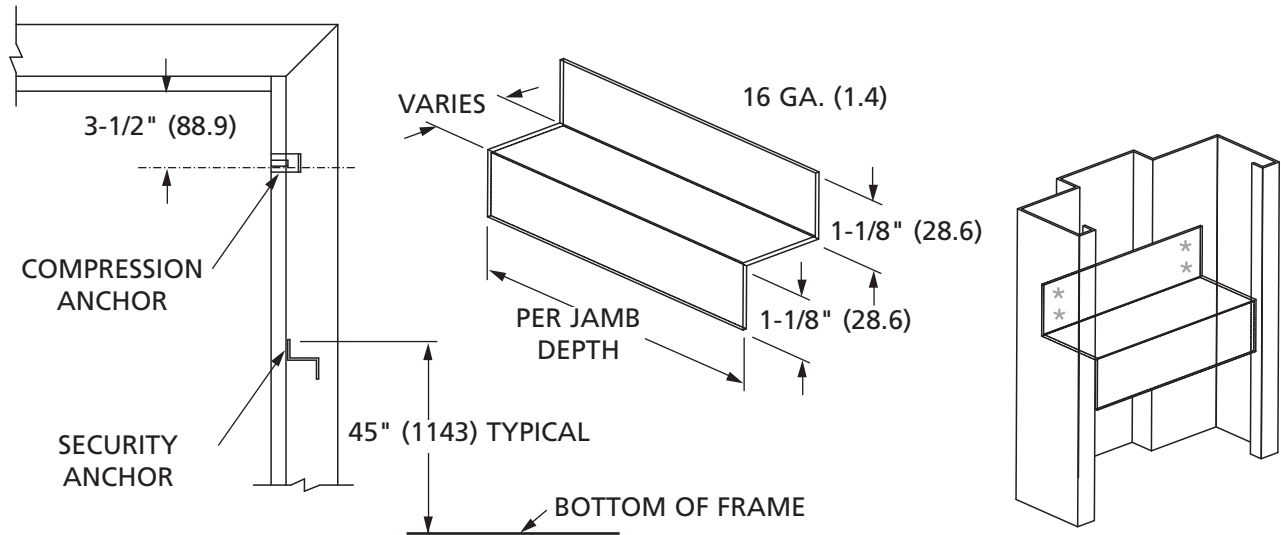

Drywall Frame Compression Anchor



ANCHOR PART NUMBER: P0026 (2" FACE)

ANCHOR PART NUMBER: P0018 (1-1/2" TO 1-3/4" FACE)

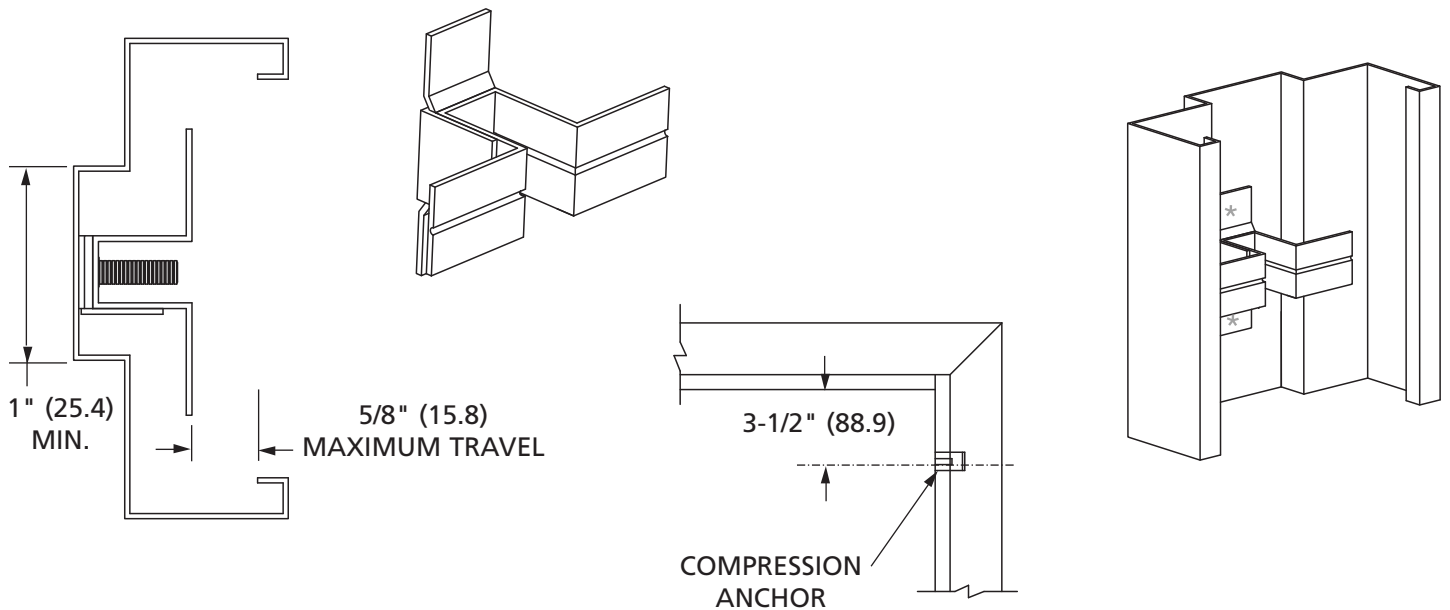

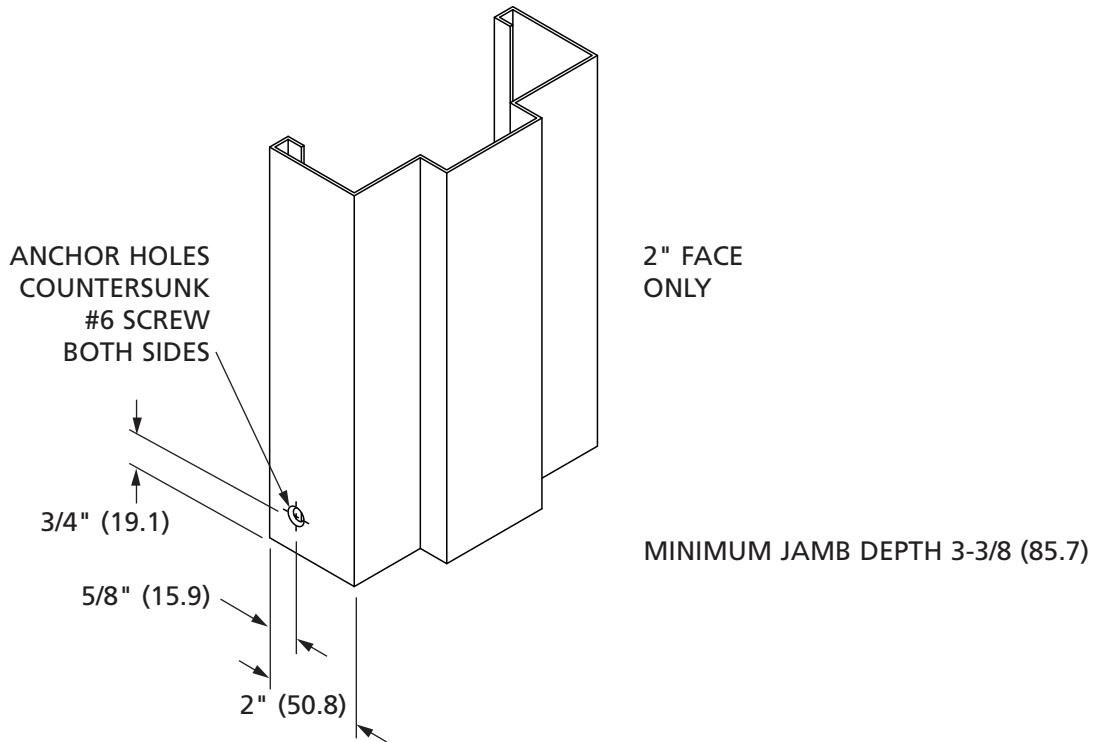

Drywall KD Frame Optional Base Anchor

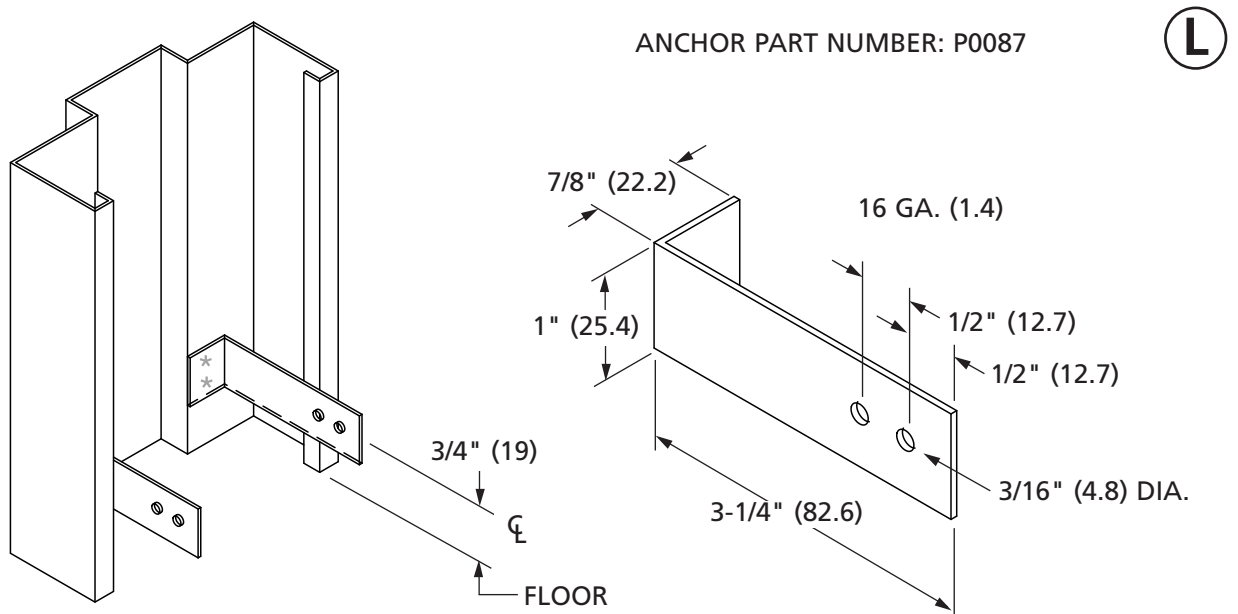

NOTE: REQUIRED ON 1-1/2" (38.1), 1-3/4" (44.5) FACE DRYWALL FRAMES. 3", 3-1/8", 3-1/4", JAMB DEPTHS.

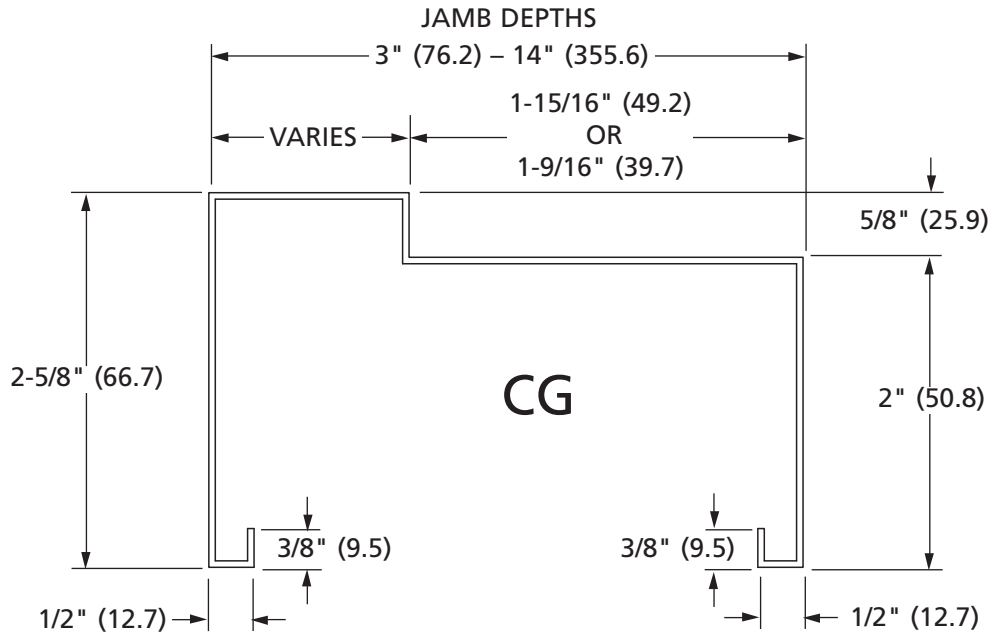

GAUGE - 18 GA. (1.2), 16 GA. (1.4)

NOTE: AVAILABLE WITH 4" (101.6) FACE HEAD WITH 4-1/2" (114.3) MINIMUM JAMB DEPTH

Compression Anchor System Narrow Jamb Depth



CG PROFILE *

1-3/8" (34.9) DOOR - 3" (76.2) JAMB DEPTH

1-3/4" (44.5) DOOR - 3" (76.2), 3-1/8" (79.4), 3-1/4" (82.6), 3-3/8" (85.7) JAMB DEPTH

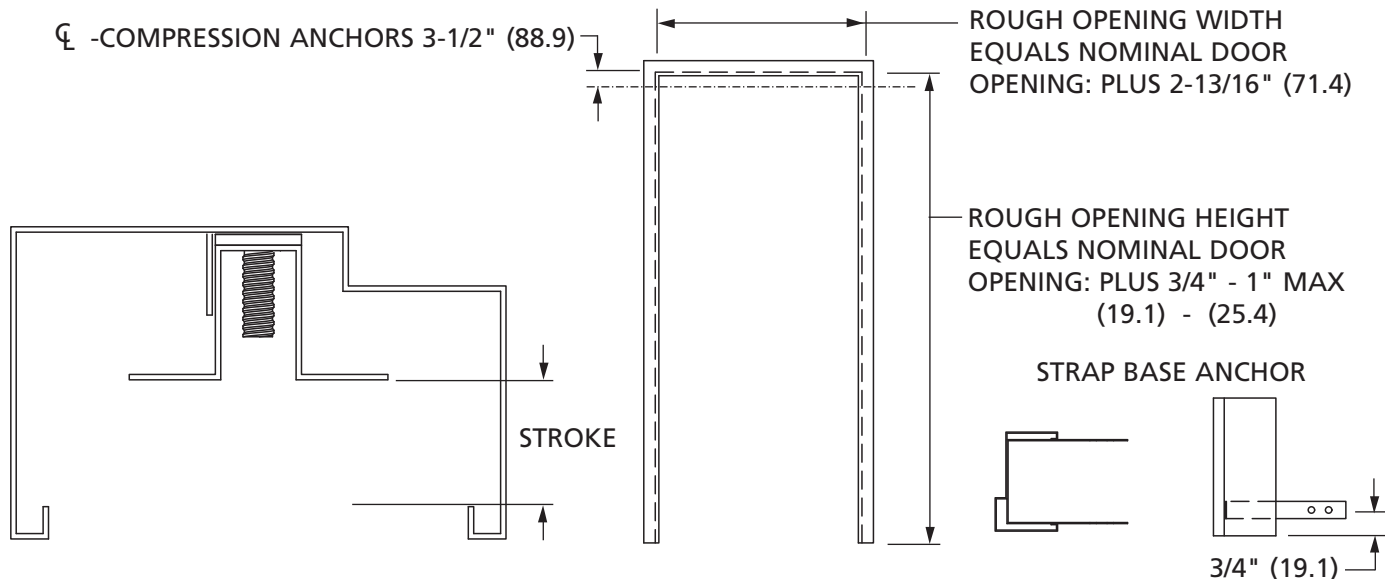

* "CG" PROFILE JAMB DEPTHS NOT LISTED ABOVE USE STD. DRYWALL ROUGH OPENING DIMENSIONS

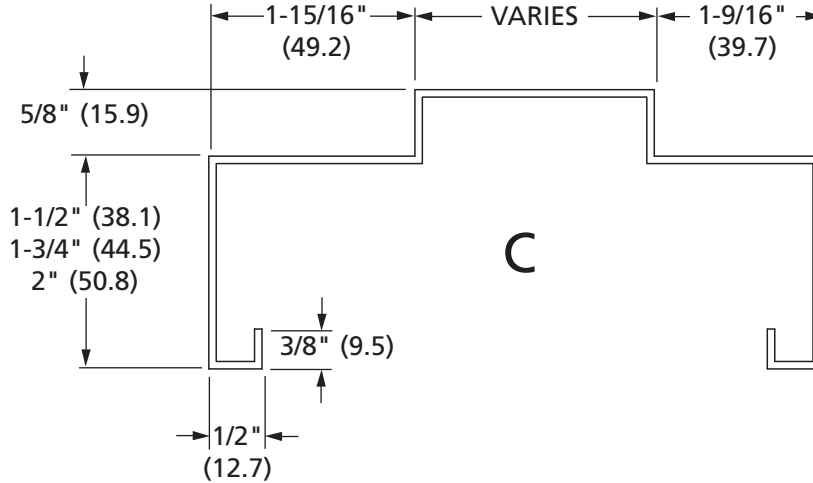

KD DRYWALL
GAUGE - 18 GA. (1.2), 16 GA. (1.4), 14 GA. (1.9) *
UNEQUAL RABBET
JAMB DEPTH 4-1/2" (114.3) THRU 14" (355.6) (1/8" (3.2) INCREMENTS)
2" (50.8) FACE AVAILABLE WITH 4" (101.6) HEADS
NOTE: 14 GA. AVAILABLE WITH 2" (50.8) FACE ONLY

Drywall KD Frame Equal Rabbet

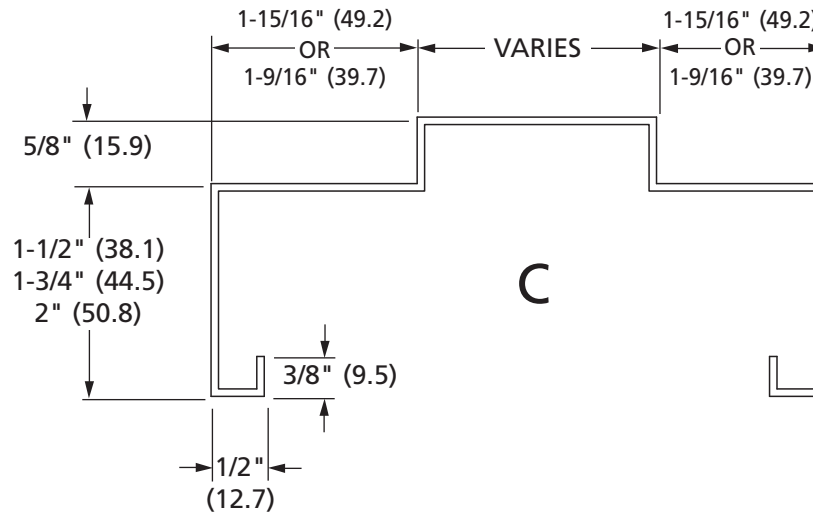

KD DRYWALL
GAUGE - 18 GA. (1.2), 16 GA. (1.4), 14 GA. (1.9) *
UNEQUAL RABBET
JAMB DEPTH 4-7/8" (123.8) THRU 14" (355.6) (1/8" (3.2) INCREMENTS)
2" (50.8) FACE AVAILABLE WITH 4" (101.6) HEADS
AVAILABLE IN COMMUNICATING FRAMES
NOTE: 14 GA. AVAILABLE WITH 2" (50.8) FACE ONLY

38 Drywall KD Frame Cased Opening

FRAME TECHNICAL DATA

April 1, 2002

CURRIES

ASSA ABLOY

ASSA ABLOY, the global leader
in door opening solutions

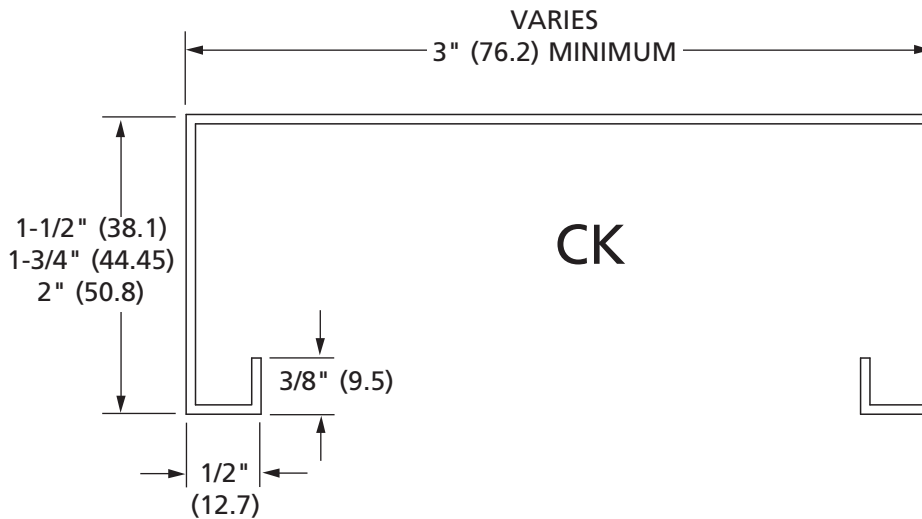

KD DRYWALL

GAUGE - 18 GA. (1.2), 16 GA. (1.4), 14 GA. (1.9)

JAMB DEPTH 3" (76.2) THRU 14" (355.6) (1/8" (3.2) INCREMENTS)

14 GA. AVAILABLE W/2" FACE ONLY

NOTE: AVAILABLE WITH 4" (101.6) FACE HEAD WITH 4-1/2" (114.3) MINIMUM JAMB DEPTH WITH 2" FACE JAMBS ONLY.

Drywall KD "CG" Profile Frame

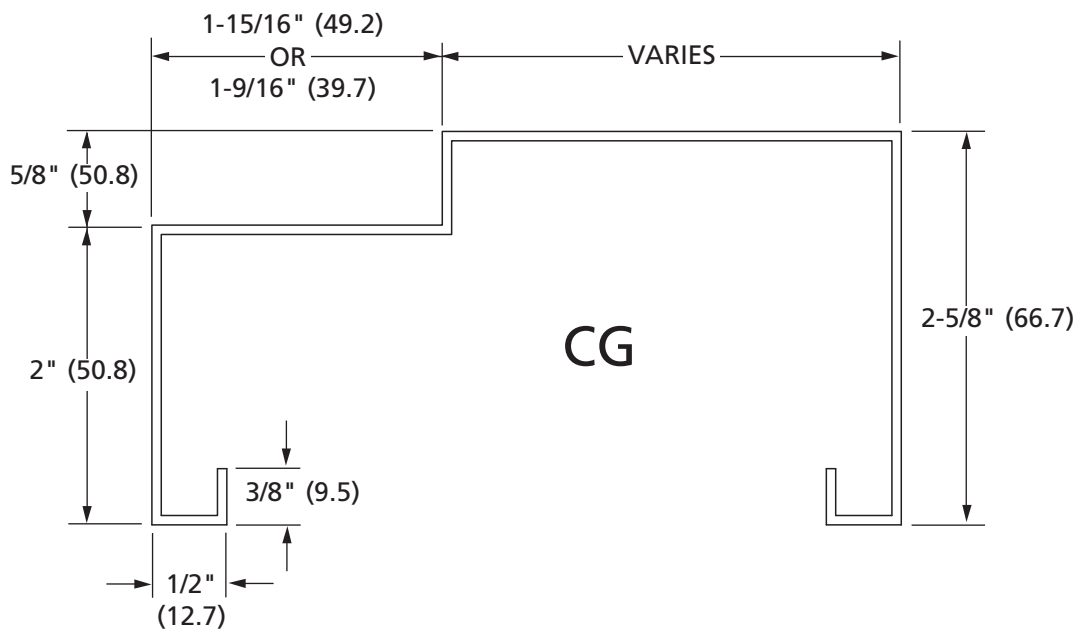

KD "CG" PROFILE DRYWALL

GAUGE - 18 GA. (1.2), 16 GA. (1.4)

JAMB DEPTH 3" (76.2) THRU 14" (355.6) (1/8" (3.2) INCREMENTS)

NOTE: 2" (50.8) AND 2-5/8" (66.7) FACE ONLY



STIFFENER PART NUMBER: P0093

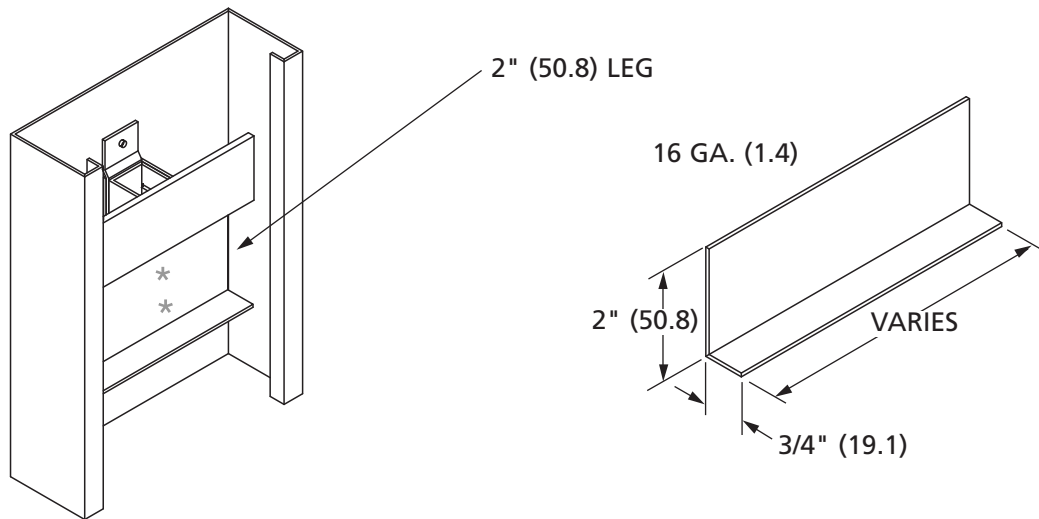

NOTE: STIFFENER ADDED TO PREVENT DISTORTION OF FRAME WHEN TIGHTENING ANCHOR

CM Profile Frames

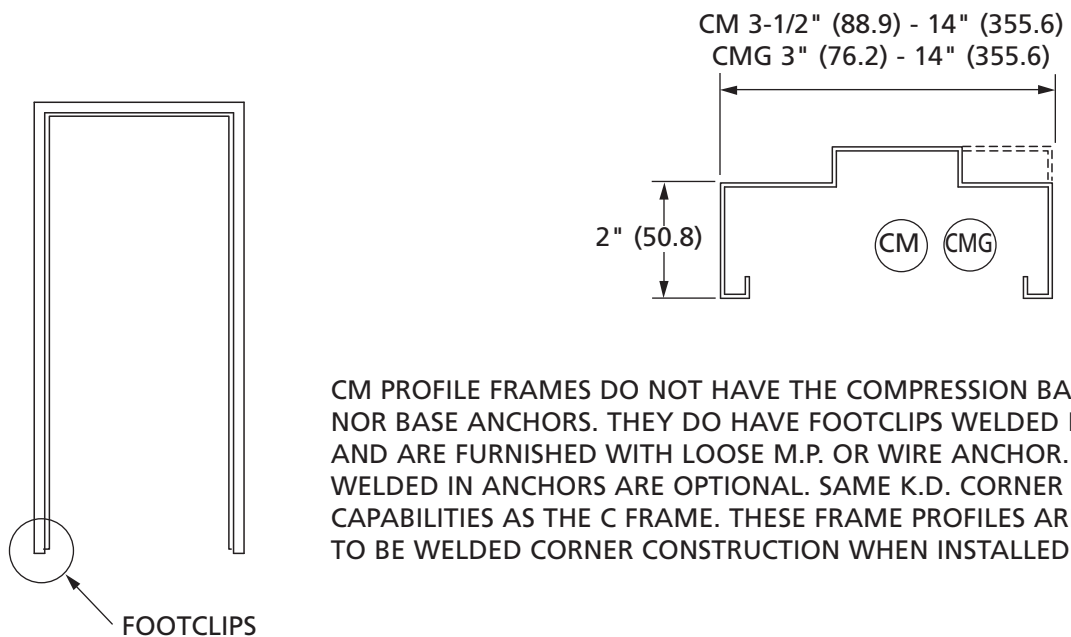

CM PROFILE FRAMES DO NOT HAVE THE COMPRESSION BAR NOR BASE ANCHORS. THEY DO HAVE FOOTCLIPS WELDED IN AND ARE FURNISHED WITH LOOSE M.P. OR WIRE ANCHOR. WELDED IN ANCHORS ARE OPTIONAL. SAME K.D. CORNER CAPABILITIES AS THE C FRAME. THESE FRAME PROFILES ARE TO BE WELDED CORNER CONSTRUCTION WHEN INSTALLED.

* MAY BE LABEL APPROVED WITH PROPERLY WELDED FRAME CORNERS.

FRAME TECHNICAL DATA

July, 2009

ASSA ABLOY, the global leader
in door opening solutions

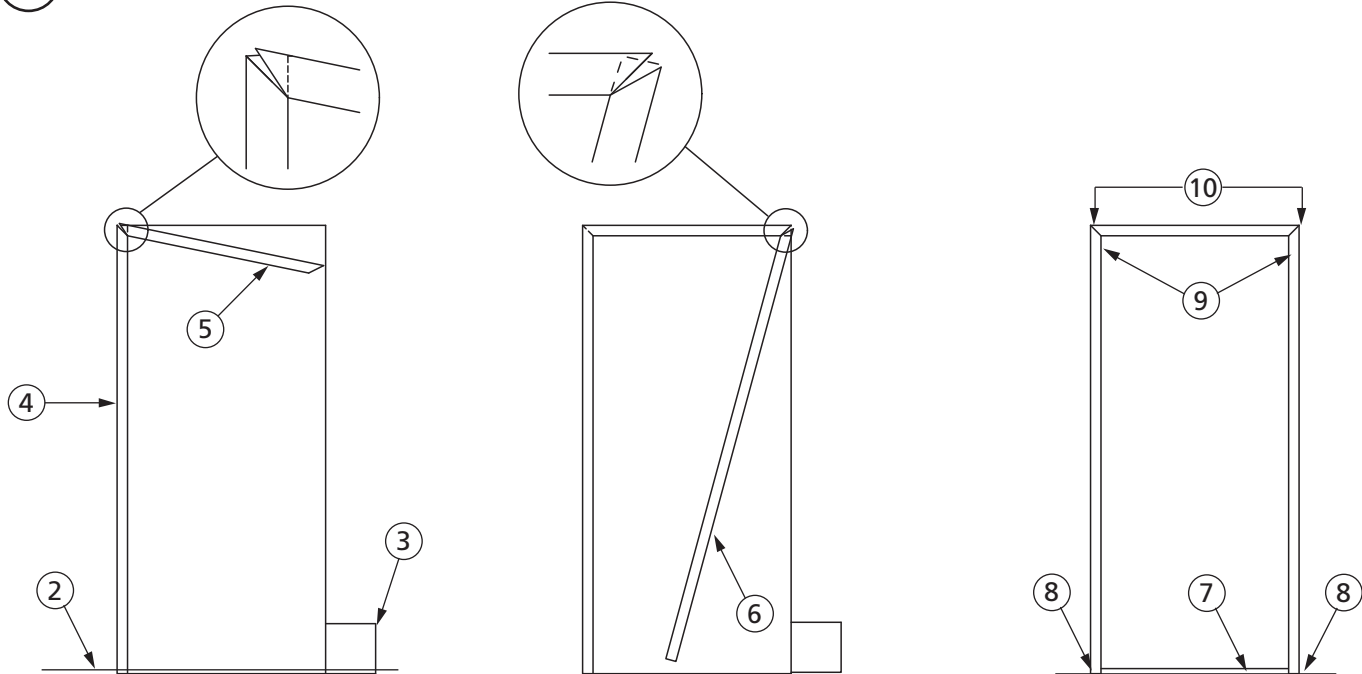

1. CONSTRUCT WALL WITH ROUGH OPENING HEIGHT EQUAL TO FINISHED OPENING HEIGHT PLUS 3/4" (19.1) TO 1" (25.4) MAX., ROUGH OPENING WIDTH IS AS FOLLOWS:
 - A) FOR 2" (50.8) FACE FRAMES-OPENING WIDTH PLUS 2-1/8" (54.0) TO 2-3/8" (60.3)
 - B) FOR 1-3/4" (44.5) AND 1-1/2" (38.1) FACE FRAMES-OPENING WIDTH PLUS 2" (50.8)
 - C) FOR "C" AND "CG" PROFILES, 3" (76.2) JAMB DEPTH 1-9/16" (39.7) RABBET AND 3" (76.2), 3-1/8" (79.4), 3-1/4" (82.6) AND 3-3/8" (85.7) JAMB DEPTH 1-15/16" (49.2) RABBET FRAMES-OPENING WIDTH PLUS 2-13/16" (71.4), ALL OTHER "C" AND "CG" PROFILE FRAMES-OPENING WIDTH PLUS 2-1/8" (54.0) TO 2-3/8" (60.3)
 - d) FOR 2" (50.8) FACE CASED OPENING - OPENING WIDTH PLUS 2-1/4" (57.2)
2. BOTTOM OF FRAME MUST SET ON A SOLID SURFACE.
3. IF WRAP-AROUND BASE ANCHOR IS USED, NOTCH DRYWALL IN THAT AREA.
4. RETRACT COMPRESSION BARS IN THE JAMBS BY TURNING SCREWS COUNTER CLOCKWISE AND INSTALL ONE JAMB IN POSITION ON WALL.
5. INSERT FRAME HEAD UNDER THE CORNER CLIPS OF THE JAMB AND RAISE INTO POSITION.
6. INSERT THE CORNER CLIPS OF THE REMAINING JAMB INTO THE OPPOSITE END OF THE HEAD AND POSITION JAMB ON WALL.
7. LOCATE A REMOVABLE FRAME SPACING BAR AT BASE OF CENTERED FRAME TO MAINTAIN PROPER OPENING WIDTH DURING INSTALLATION.
8. LEVEL, SQUARE AND PLUMB FRAME AND INSTALL BASE ANCHOR SCREWS THROUGH COUNTERSINK HOLES IN FRAME FACE AND INTO FLOOR PLATE.
9. SQUARE TOP OF FRAME AND TIGHTEN COMPRESSION BARS BY TURNING SCREWS CLOCKWISE. (DO NOT OVERTIGHTEN).
10. INSTALL (4) NO. 8 X 1/2" (12.7) SHEET METAL SCREWS AT THE CORNERS OF THE HEAD TO ATTACH HEAD TO JAMBS (REQUIRED FOR FIRE RATED FRAMES).



- NOTE A:** ROUGH OPENING HEIGHT FOR 2" (50.8) FACE FRAMES EQUALS GLASS OPENING SIZE PLUS 2-1/2" (63.5) INCLUDING CASED OPENING
NOTE A: ROUGH OPENING HEIGHT FOR 1-1/2" (38.1) & 1-3/4" (44.5) FACE FRAMES EQUALS GLASS OPENING SIZE PLUS 2" (50.8)
- NOTE B:** ROUGH OPENING WIDTH FOR 2" (50.8) FACE FRAMES EQUALS GLASS OPENING SIZE PLUS 2-1/2" (63.5) INCLUDING CASED OPENING
ROUGH OPENING WIDTH FOR 1-1/2" (38.1) & 1-3/4" (44.5) FACE FRAMES EQUALS GLASS OPENING SIZE PLUS 2" (50.8)

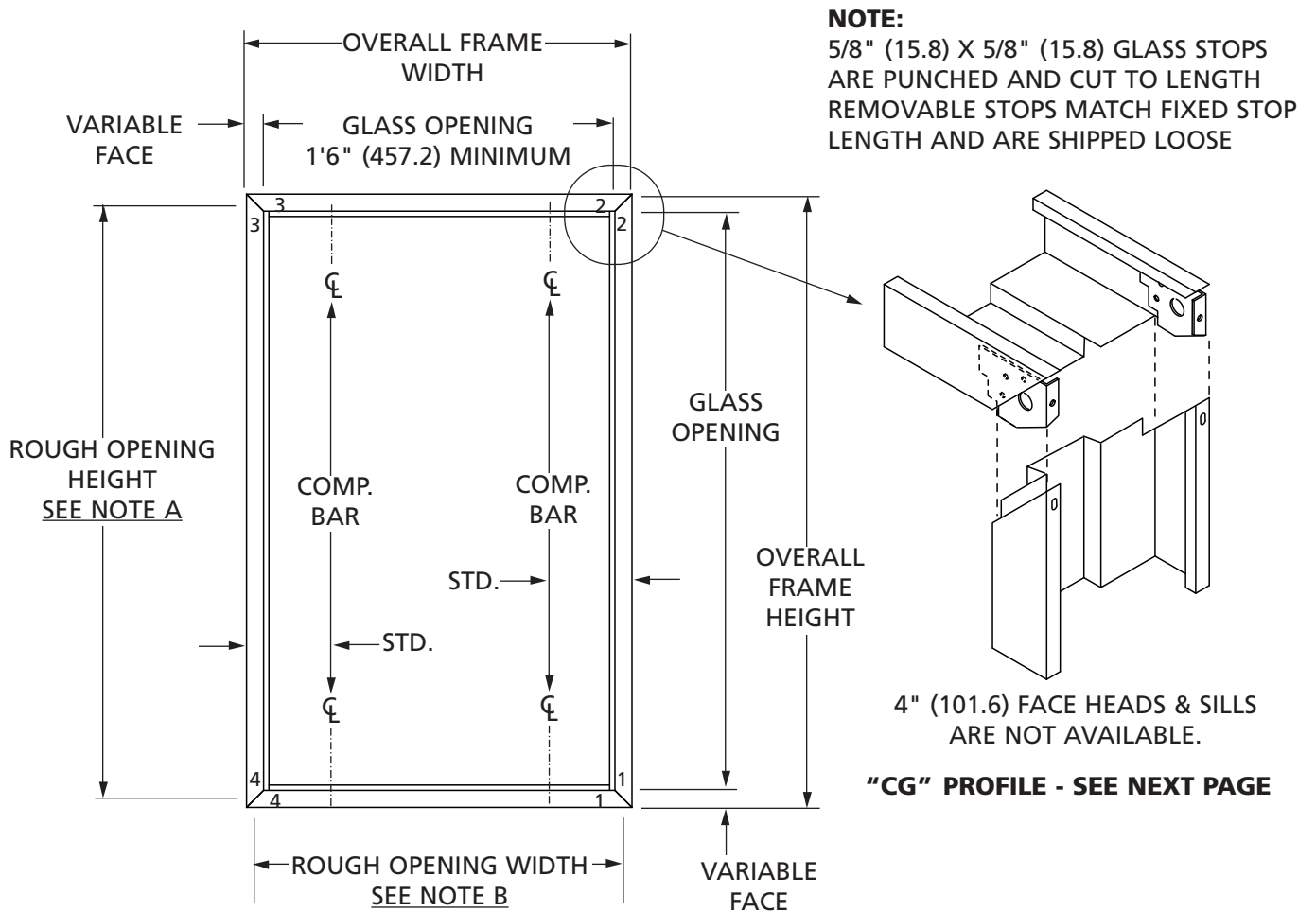

KD BORROWED LITE (DRYWALL FRAME ONLY)

ORDER OF INSTALLATION - A) PLACE RIGHT SIDE VERTICAL JAMB MEMBER INTO OPENING; B) INSTALL SILL MEMBER AND ASSEMBLE CORNER #1; C) THEN INSTALL HEAD MEMBER AND ASSEMBLE CORNER #2 D) WHILE INSTALLING THE REMAINING LEFT VERTICAL JAMB MEMBER IT MAY BE NECESSARY TO EXTEND THE HEAD (CORNER #3) AND SILL (CORNER #4) TO THEIR ROUGH OPENING LIMITATIONS FOR EASIER INSTALLATION; E) THEN ASSEMBLE CORNER #3 AND FINALLY SNAP INTO POSITION THE REMAINING CORNER #4; F) INSTALL SCREWS THROUGH FRAME RETURNS INTO CORNER CLIPS; G) ADJUST COMPRESSION BARS UNTIL LEVEL AND PLUMB.

42 Single Rabbet Drywall KD Borrowed Lite FRAME TECHNICAL DATA

July, 2007

CURRIES

ASSA ABLOY

ASSA ABLOY, the global leader
in door opening solutions

L

"CG" PROFILE - COMPRESSION BAR RABBET MOUNTED.

JAMB DEPTHS INCLUDE 3" (76.2), 3-1/8" (79.4), 3-1/4" (82.5), 3-3/8" (85.7) X 1-15/16" (49.2) RABBET
AND 3" (76.2) X 1-9/16" (39.7) RABBET

NOTE A: ROUGH OPENING HEIGHT FOR 2" (50.8) FACE FRAMES EQUALS
GLASS OPENING SIZE PLUS 2-3/4" (69.8)

NOTE B: ROUGH OPENING WIDTH FOR 2" (50.8) FACE FRAMES EQUALS
GLASS OPENING SIZE PLUS 2-1/2" (63.5)

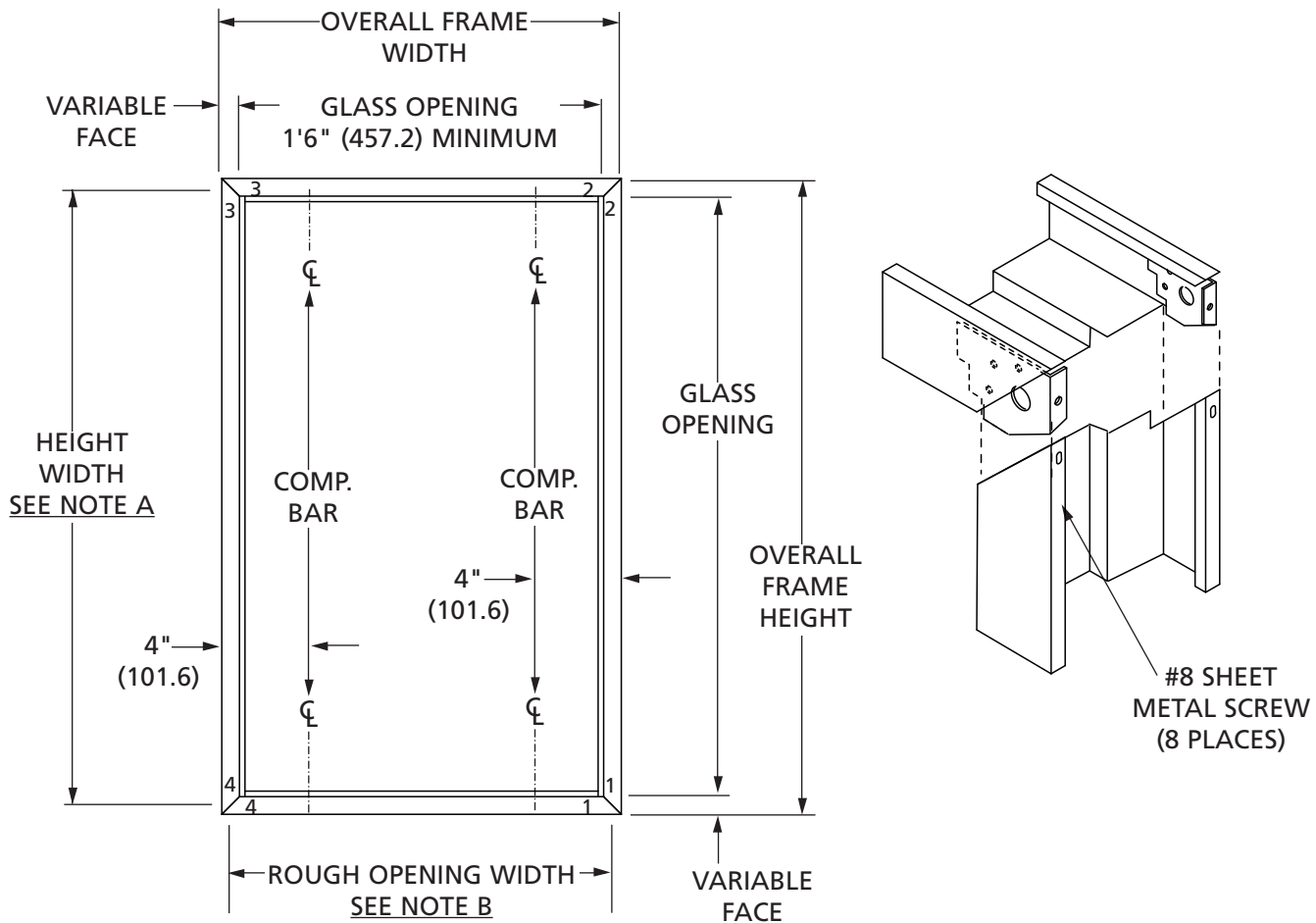

KD BORROWED LITE (DRYWALL FRAME ONLY)

ORDER OF INSTALLATION - A) PLACE RIGHT SIDE VERTICAL JAMB MEMBER INTO OPENING; B) INSTALL SILL MEMBER AND ASSEMBLE CORNER #1; C) THEN INSTALL HEAD MEMBER AND ASSEMBLE CORNER #2 D) WHILE INSTALLING THE REMAINING LEFT VERTICAL JAMB MEMBER IT MAY BE NECESSARY TO EXTEND THE HEAD (CORNER #3) AND SILL (CORNER #4) TO THEIR ROUGH OPENING LIMITATIONS FOR EASIER INSTALLATION; E) THEN ASSEMBLE CORNER #3 AND FINALLY SNAP INTO POSITION THE REMAINING CORNER #4; F) INSTALL SCREWS THROUGH FRAME RETURNS INTO CORNER CLIPS. G) ADJUST COMPRESSION BARS UNTIL LEVEL AND PLUMB.

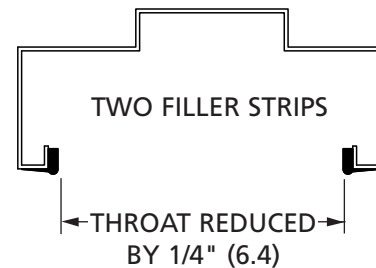
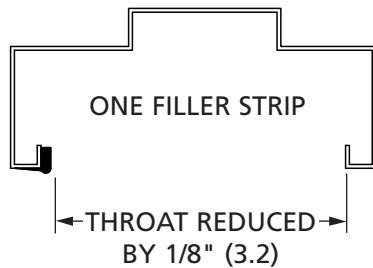
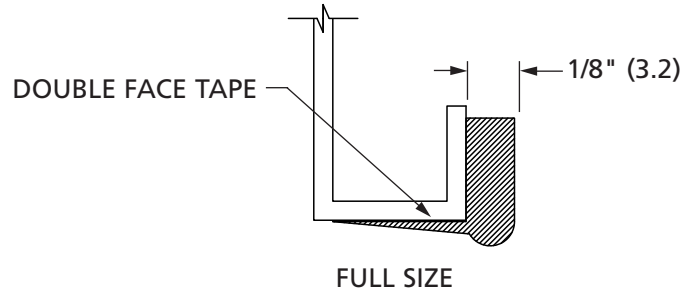

THROAT FILLER STRIPS ARE MADE OF WHITE RIGID PVC WITH RESILIENT DOUBLE FACE TAPE FOR APPLICATION TO THE FRAME BACKBEND OR AFTER THE FRAME HAS BEEN INSTALLED.

SUPPLIED IN LENGTHS OF 7 FT. 3 IN. (2209.8) TO ACCOMMODATE MOST JAMB HEIGHTS WITH A CONTINUOUS STRIP.

NOTE: THROAT FILLER IS NOT ALLOWED ON LABEL FRAMES

INSTALLATION

1. FOR BEST RESULTS INSTALL FRAME IN OPENING FIRST. DO NOT TIGHTEN COMPRESSION ANCHORS.
2. CUT JAMB FILLER STRIPS TO OVERALL LENGTH OF JAMB BACKBEND. CUT HEAD FILLER STRIP 1" (25.4) UNDER OVERALL LENGTH OF HEAD BACKBEND.
3. REMOVE PROTECTIVE FILM FROM ADHESIVE TAPE AND APPLY FILLER STRIPS TO FRAME BACKBENDS WITH 1/8" (3.2) THICK LEG BETWEEN BACKBEND RETURN AND WALL. APPLY PRESSURE TO SEAT FIRMLY.
4. SQUARE FRAME, TIGHTEN COMPRESSION ANCHORS, INSTALL BASE ANCHORS AND RESEAT FILLER STRIPS IF NECESSARY.

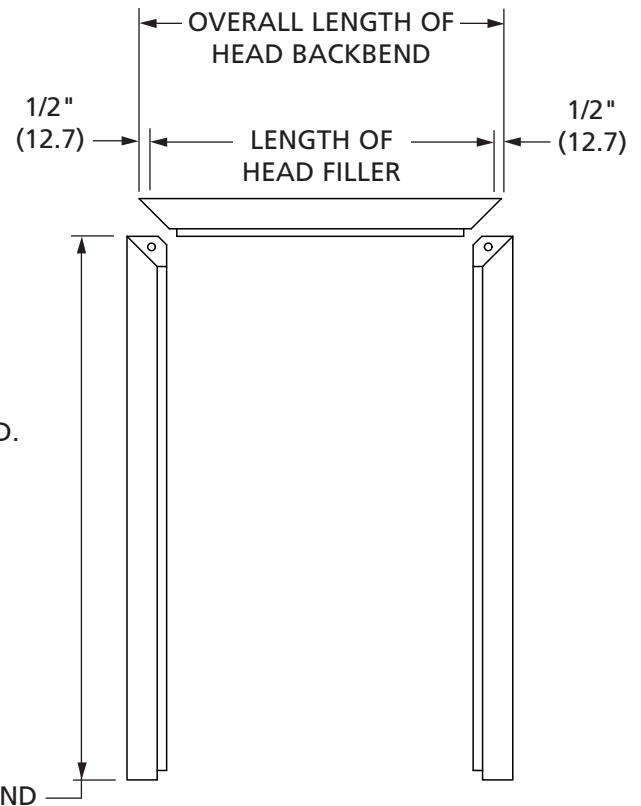

FILLER EQUALS OVERALL LENGTH OF BACKBEND