

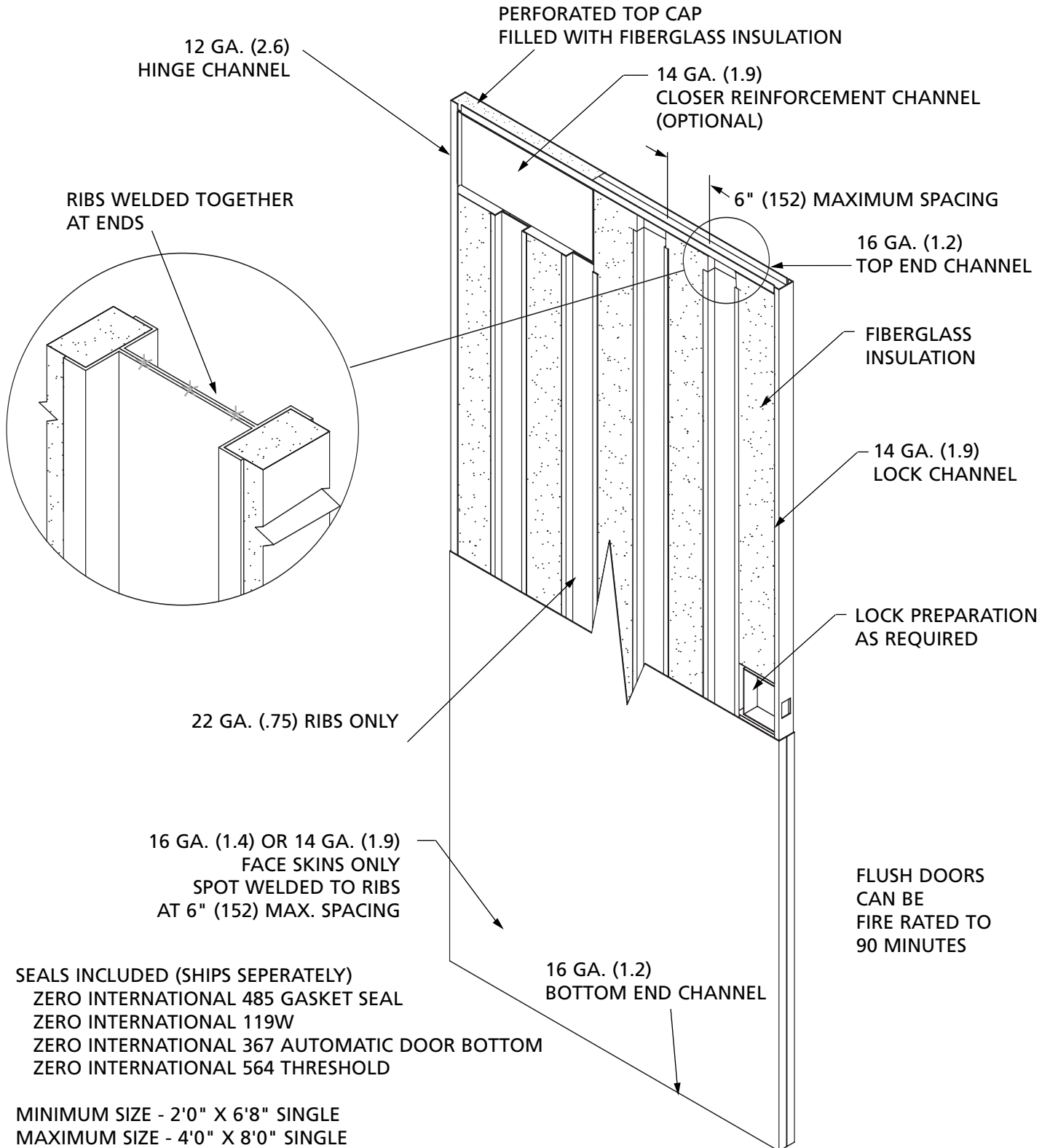

**STC 46 OPERABLE**  
**TESTED TO: ASTM E 90-04 AND ASTM E 1332-90**  
**BUILT IN COMPLIANCE WITH SDI 128 AND HMMA 865-03**



SEALS INCLUDED (SHIPS SEPERATELY)  
ZERO INTERNATIONAL 485 GASKET SEAL  
ZERO INTERNATIONAL 119W  
ZERO INTERNATIONAL 367 AUTOMATIC DOOR BOTTOM  
ZERO INTERNATIONAL 564 THRESHOLD

MINIMUM SIZE - 2'0" X 6'8" SINGLE  
MAXIMUM SIZE - 4'0" X 8'0" SINGLE

**SEE PAGE 7B FOR ADDITIONAL NOTES**

# 7A 757 STC 43 Door Construction

## DOOR TECHNICAL DATA

March, 2010



**CURRIES**<sup>®</sup>

**ASSA ABLOY**

ASSA ABLOY, the global leader  
in door opening solutions

**STC 43 OPERABLE  
TESTED TO: ASTM E 90-04 AND ASTM E 1332-90  
BUILT IN COMPLIANCE WITH SDI 128 AND HMMA 865-03**

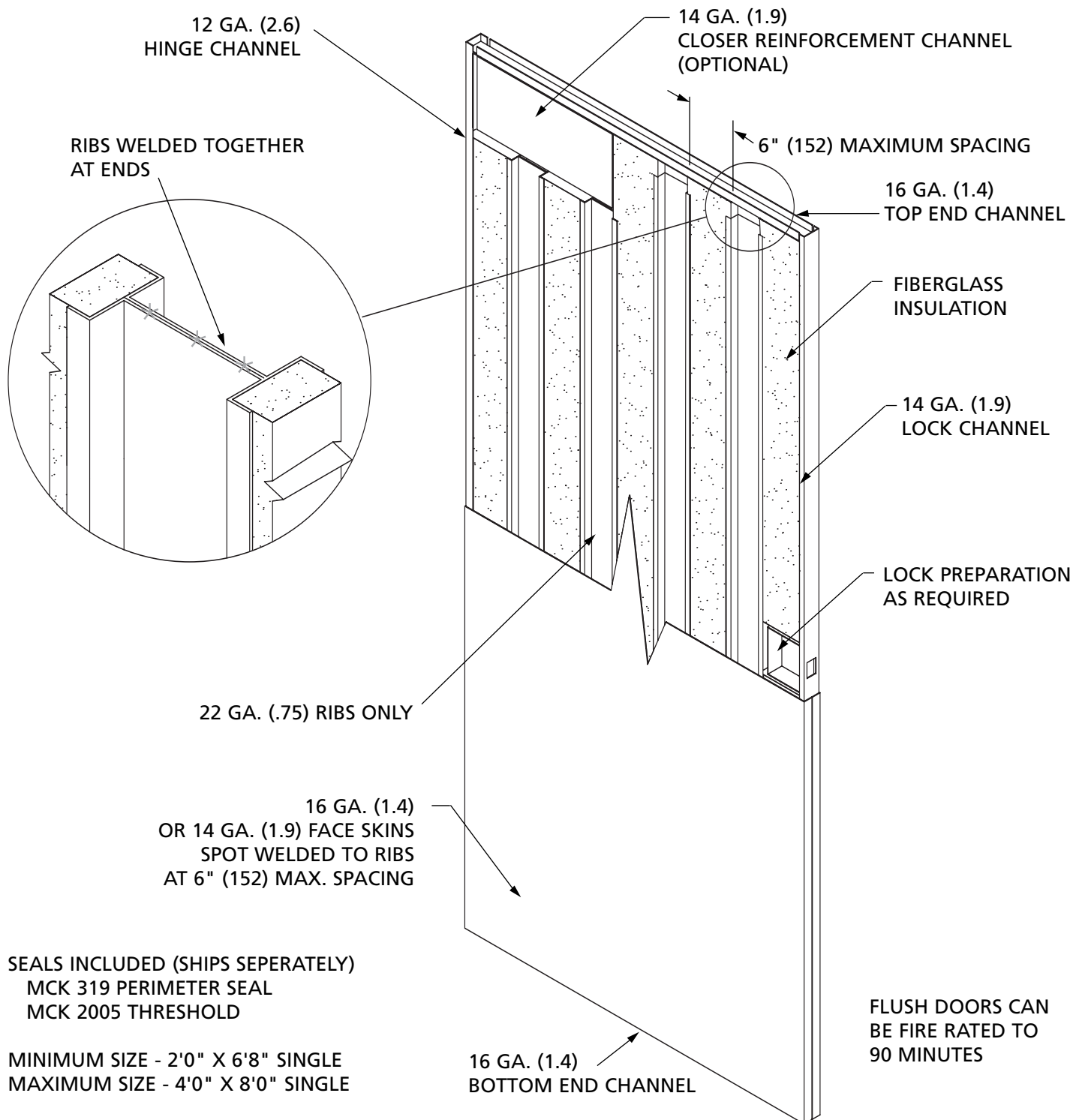

**SEE PAGE 7B FOR ADDITIONAL NOTES**

**NOTES FOR ALL CURRIES STC (32-46) PRODUCTS:**

1. MUTES NOT ALLOWED
2. SURFACE CLOSER ONLY
3. STC LABEL APPLIED TO DOOR ONLY
4. MASONRY APPLICATIONS MUST BE GROUTED
5. STUD WALL APPLICATION MUST BE FILLED WITH SOUND DEADENING MATERIAL
6. ONLY FLUSH DOORS AVAILABLE
7. MAXIMUM 90 MINUTE FIRE RATING
8. BUILT IN COMPLIANCE WITH SDI 128 AND HMMA 865-03

**STC 32 OPERABLE**

TESTED TO: ASTM E 90-04 AND ASTM E 1332-90  
SEALS INCLUDED (SHIP SEPARATELY)  
PEMKO 319 PERIMETER SEAL  
PEMKO 2005 THRESHOLD

MINIMUM SIZE: 2'0" X 6'8" SINGLE  
MAXIMUM SIZE: 4'0" X 8'0" SINGLE

**STC 38 OPERABLE**

TESTED TO: ASTM E 90-02 AND ASTM E 1332-90  
SEALS INCLUDED (SHIP SEPARATELY)  
PEMKO 297 PERIMETER SEAL  
PEMKO 181 THRESHOLD

MINIMUM SIZE: 2'0" X 6'8" SINGLE  
MAXIMUM SIZE: 4'0" X 8'0" SINGLE

**STC 41 OPERABLE**

TESTED TO: ASTM E 90-02 AND ASTM E 1332-90  
SEALS INCLUDED (SHIP SEPARATELY)  
PEMKO 319 PERIMETER SEAL  
PEMKO 2005 THRESHOLD

MINIMUM SIZE: 2'0" X 6'8" SINGLE  
MAXIMUM SIZE: 4'0" X 8'0" SINGLE  
TEMPERATURE RISE RATING: 450°

**STC 41 OPERABLE FOR PAIRS**

TESTED TO: ASTM E 90-04 AND ASTM E 1332-90  
SEALS INCLUDED (SHIP SEPARATELY)  
ZERO 81455 GASKET SEAL  
ZERO 139A W SEAL AND ASTRAGAL  
ZERO 365A AUTO DOOR BOTTOM  
ZERO 564A THRESHOLD

MINIMUM SIZE: 4'0" X 6'8" PAIRED  
MAXIMUM SIZE: 8'0" X 8'0" PAIRED

# 7C 757 STC 50, 52, and 54 Sound Door Construction

## DOOR TECHNICAL DATA

**CURRIES**

**ASSA ABLOY**

March, 2010



ASSA ABLOY, the global leader  
in door opening solutions



**STC 50, 52, AND 54 OPERABLE  
TESTED TO: ASTM E90-09, E413-04, E1332-90, AND E2235  
BUILT IN COMPLIANCE WITH SDI 128 AND HMMA 865-03**

FLUSH ONLY

HANDED DOORS ONLY

3/8" UNDERCUT

CAN BE FIRE RATED TO 180 MINUTES (STC 50  
AND 52 ONLY)  
STC 54 – NON – RATED ONLY

1-3/4" THICK

### FRAMES:

MUST BE SINGLE OR DOUBLE RABBET,  
CONTINUOUSLY WELDED. 16 GAUGE OR  
14 GAUGE. MUTES ARE NOT ALLOWED.  
FRAMES MUST BE GROUTED TO ACHIEVE  
STC RATING.

### HARDWARE ALLOWED

### HINGES:

4-1/2" STANDARD OR HEAVY  
5" STANDARD OR HEAVY  
OFFSET PIVOTS  
CAMLIFT

### LOCKS:

CYLINDRICAL  
MORTISE

### SEALS INCLUDED AND REQUIRED:

STC 50 – ZERO 475, 119, AND 564  
STC 52 – ZERO 870, 119, 564, AND 367  
STC 54 – ZERO 770, 119, 118, 564, AND 367

MINIMUM SIZE - 2'0" X 6'8" SINGLE  
MAXIMUM SIZE - 4'0" X 8'0" SINGLE

