

Installation and Troubleshooting Guide

INSTALLATION AND TROUBLESHOOTING

June, 2014

Hardware Installation	1
Door Installation	3-5
KD Drywall	6-7
KD Sidelight Installation	8
Troubleshooting Checklist	9
Troubleshooting Door and Frame Installation	10-12
Correcting Door and Frame Fitting Problems	13-14

Preparation of Holes for Threaded Fasteners

The key to maximum strength in the installation of hardware using threaded fasteners is the proper sizing and depth of the tapped hole. Since screw sizes are normally specified and usually furnished by the hardware manufacturer, it is necessary to provide proper metal thickness and tapped hole size to make the installation as strong as intended.

METAL GAUGE	SCREW SIZE			
	8-32	10-24	12-24	1/4-20
20	1	7/8	7/8	3/4
18	1-1/2	1-1/5	1-1/5	1
16	2	1-1/2	1-1/2	1-1/2
14	2-1/2	2	2	2
12	3-1/3	2-1/2	2-1/2	2

Table 1

Listing of several metal thicknesses and the corresponding number of threads engaged for various commonly used machine screw sizes.

SCREW SIZE	DRILL SIZE	HOLE DIA.
8-32	29	.136
10-24	25	.149
12-24	16	.177
1/4-20	7	.201

Table 2

Listing of tap drill sizes to provide proper percent thread engagement for the same range of sizes.

SCREW SIZE	DRILL SIZE	HOLE DIA.
8	27	.144
10	19	.166
12	11	.191
1/4	2	.221

Table 3

Listing of the recommended pilot hole sizes for thread-cutting screws.

NOTE:

A rule of thumb for most hardware installations, using standard coarse machine screw threads, is to provide a thread engagement of minimum 2 to 2-1/2 complete threads with approximately 75% engagement between each screw thread and its' mating thread.

FOR BEST RESULTS:

Read and follow the hardware manufacturer's instructions for the installation of each type of hardware.

INSTALLATION AND TROUBLESHOOTING

June, 2014



ASSA ABLOY, the global leader
in door opening solutions

Installation Steps

- 1** Attach the hinges loosely to the door with the heads of the pivot pins toward the top.
- 2** Support the door adjacent to the hinge jamb in a position 90° to the frame. A wood block close in thickness to the undercut of the door makes a good support.
- 3** Align the hinges with the reinforcing on the jamb and insert the mounting screws beginning with the top hinge.
- 4** Tighten all screws in all hinges and close door to check clearances between door and frame.

Clearance Adjustments

If clearances at lock and hinge jambs need adjustment, remove screws (one leaf at a time) and insert narrow shims (3/8" wide by length equal to hinge height) as needed, to shift the door by small increments in desired direction. See figure 1 and 2.

NOTE:

If frame is square and plumb the clearances should be approximately 1/8" at the top, 3/32" at hinge and lock edges and 5/8" undercut at the floor.

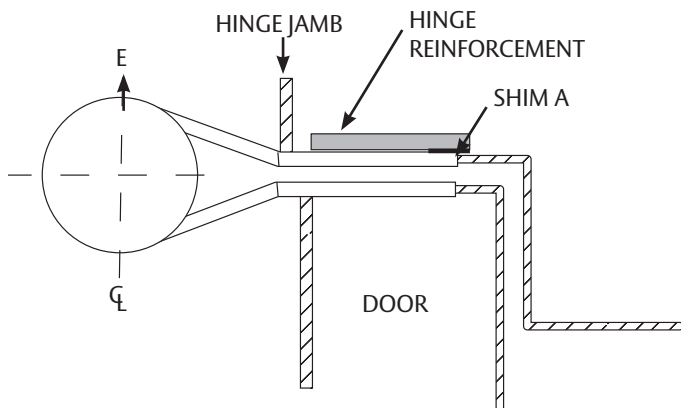

Figure 1

Using shim (A) only, will move both door and centerline of hinge barrel in direction of arrow "E".

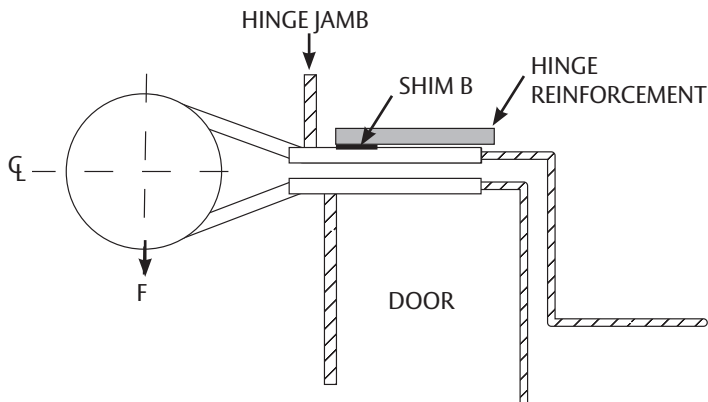

Figure 2

Using shim (B) only, both door and centerline of hinge barrel will move in the direction of arrow "F".

Clearance Adjustments (cont.)

SHIM INFORMATION

Various materials can be used for shims, from door packaging strapping to stock shim material. The more dense the shim material is (least compressible) the better, so as to decrease the possibility for screws loosening as the shim takes "set". The size should be 3/8" wide and 4-1/2" long for a 4-1/2" hinge or 5" long for a 5" hinge, etc.

Following are some typical clearance problems and hinge shimming methods which can be used to improve the situation. See page 3 for shim installation instructions.

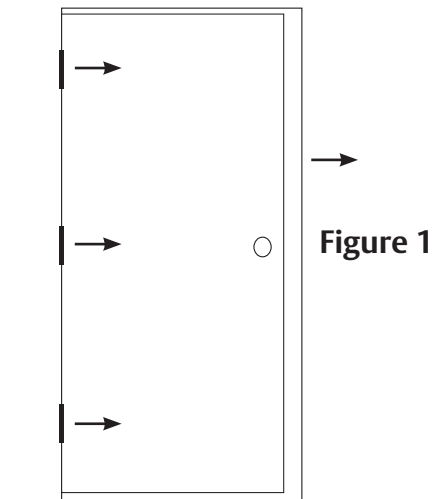

Figure 1

Tight hinge side clearance and/or excessive lock side clearance

Even but excessive clearance between the strike jamb and the lock edge of the door can be improved by placing equal sized shims (B) between each jamb hinge reinforcing and the hinge leaf to move the door and hinge barrel toward the strike jamb.

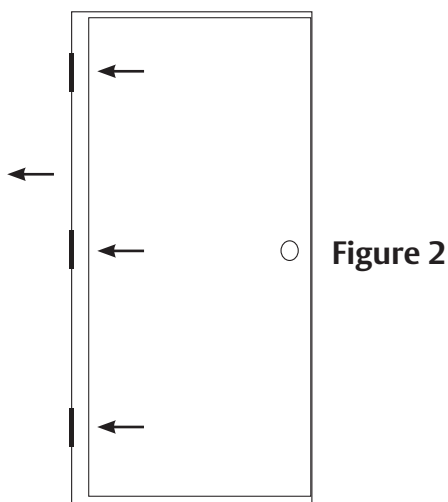

Figure 2

Tight Lock side clearance and/or excessive hinge side clearance

Even but tight clearance between the strike jamb and the lock edge of the door can be improved by placing equal sized shims (A) between each jamb hinge reinforcing and the hinge leaf to move the door and hinge barrel toward the hinge jamb. Further adjustments can be made by placing two equal sized shims (A) behind each door hinge reinforcing.

NOTE:

Shim (A) when too thick can cause hinge bind when the door is closed, especially when weatherstrip is applied to the hinge rabbet.

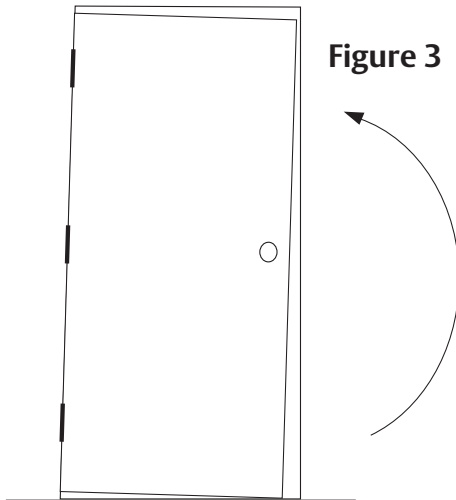
Clearance Adjustments (cont.)**Figure 3****Out of square hinge jamb or strike jamb****Toe Out:**

Frame openings which are wider at the base than at the head will cause wider clearance at the lower lock edge and at the top as shown in Figure 3. This condition can be improved by placing shim (B) between the jamb and door hinge reinforcings respectively at the bottom hinge leaves.

Further adjustment can be made by placing shim (A) behind the top hinge which will in effect rotate the door about the middle hinge.

If the strike jamb is toed out, try placing shim (B) at the middle hinge as well.

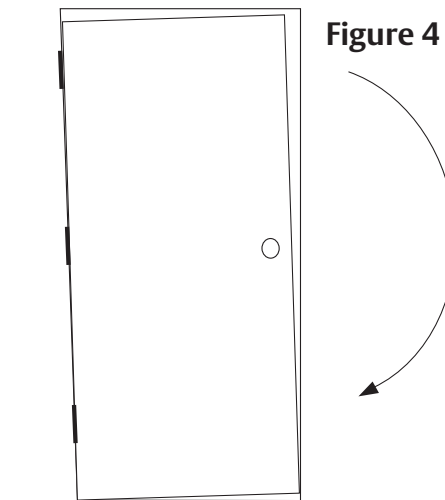
**Figure 4****Out of square hinge jamb or strike jamb****Toe In:**

Frame openings which are narrower at the base than at the head will cause tight clearance at the lower lock edge and at the top as shown in Figure 4.

This can be improved by placing shim (A) behind the bottom hinge and possibly the middle hinge as well.

Further fine adjustment can be made by placing thin shim (B) at the top hinge.

**Frame Installation Instructions
for Steel Stud Wall Construction**

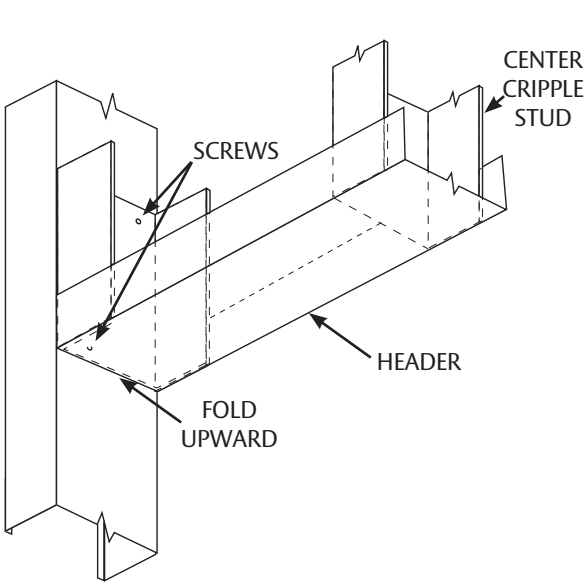

RECOMMENDED

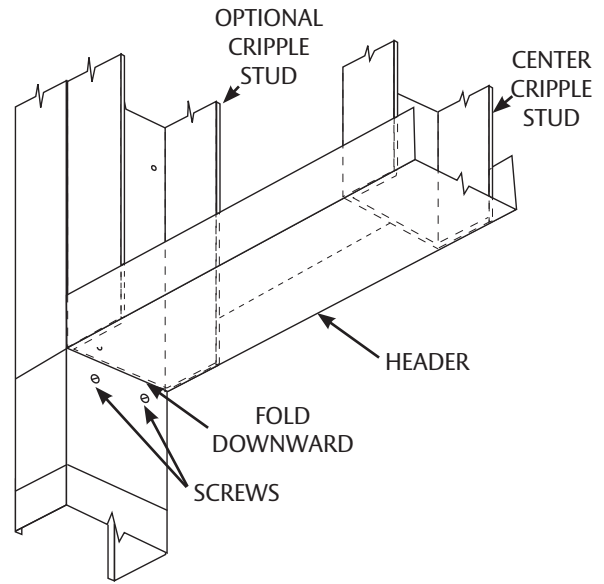

ACCEPTABLE

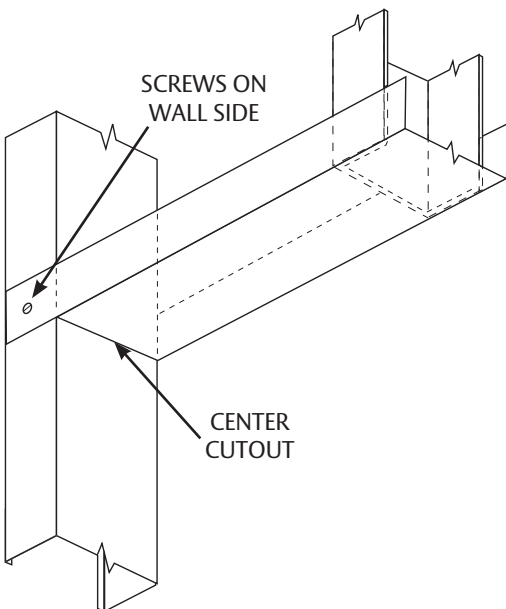

NOT RECOMMENDED

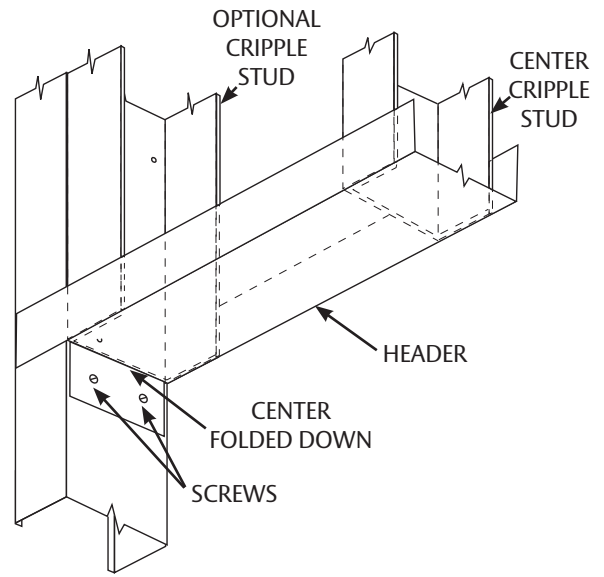

ACCEPTABLE

Frame Installation Instructions for Steel and Wood Stud Wall Construction

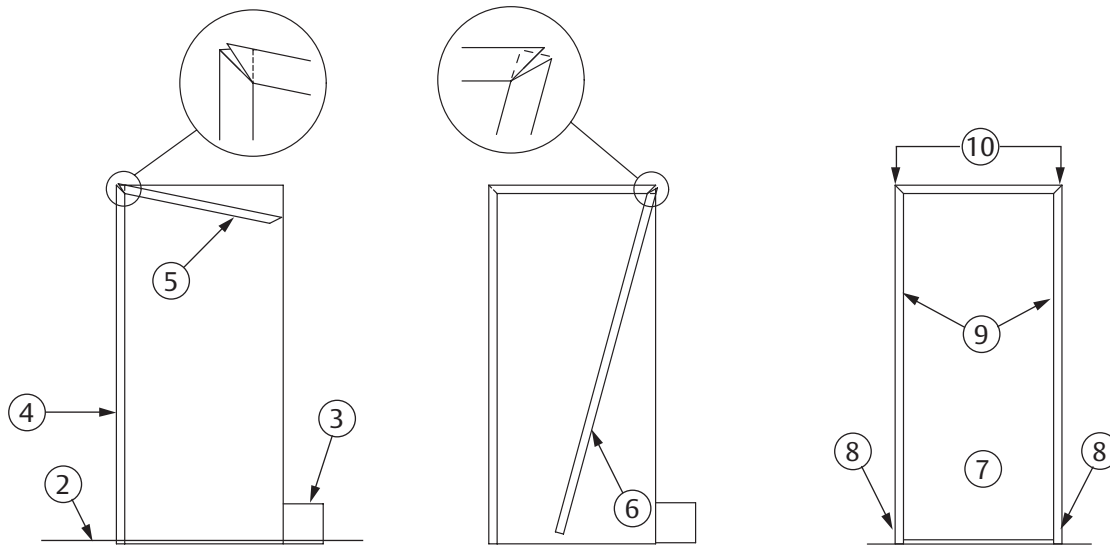

1. Construct wall with rough opening height equal to finished opening height plus 3/4" to 1" maximum, rough opening width is as follows:
 - A) For 2" face frames-opening width plus 2-1/8" to 2-3/8".
 - B) For 1-3/4" and 1-1/2" face frames-opening width plus 2".
 - C) For "G" and "CG" profiles, 3" jamb depth 1-9/16" rabbet and 3", 3-1/8", 3-1/4" and 3-3/8" jamb depth 1-15/16" rabbet frames-opening width plus 2-13/16", all other "G" and "CG" profile frame-opening with plus 2-1/8" to 2-3/8".
2. Bottom of frame must set on a solid surface.
3. If wrap-around base anchor is used, notch drywall in that area.
4. Retract compression bars in the jambs by turning screws counter clockwise and install one jamb in position on wall.
5. Insert frame head under the corner clips of the jamb and raise into position.
6. Insert the corner clips of the remaining jamb into the opposite end of the head and position jamb on wall.
7. Locate a removable frame spacing bar at base of centered frame to maintain proper opening width during installation.
8. Level, square, and plumb frame and install base anchor screws through countersink holes in frame face and into floor plate.
9. Square top of frame and tighten compression bars by turning screw clockwise.
NOTE: Do not over tighten!
10. Install (4) No. 8 x 1/2 sheet metal screws at the corners of the head to attach head to jambs.
NOTE: Required for U.L. rated frames.

8 KD SideLight™ Installation

INSTALLATION AND TROUBLESHOOTING

June, 2014

CURRIES®

ASSA ABLOY

ASSA ABLOY, the global leader
in door opening solutions

The Basics

- (rough opening height) = (finished opening height + 1")
- (rough opening width) = (finished opening width + 2")
- Frame must be set on a solid surface

**SUPER
SIMPLE**
KD SideLight

Required Tools

Level	String	Pencil
Square	Rubber Mallet	Spacing Bar
Phillips Screwdriver	Wood Block	Tape Measure

Step by Step

1. With door jamb in position, insert frame head over the corner clips of the door jamb and raise into position.
2. Insert the corner clips of the remaining jamb into the opposite end of the head and position second jamb on wall.
3. With frame approximately centered in rough opening width, level, square and plumb frame, using compression anchors, and install base anchor screws into jamb farthest from mullion (usually door hinge jamb).
4. Slip top of mullion over mullion stirrup, with base of mullion tipped toward unsecured jamb. If sidelight is narrow, the mullion base will have to tip toward the door jamb. Slide mullion into place so that it is approximately vertical.
5. Push base of unsecured jamb back on wall and slip sill into place.
6. Locate a removable frame spacing bar in door opening to maintain proper opening width.
7. Position base of mullion against frame spacing bar.
8. Tighten sidelight jamb against sill with compression anchor.
9. Run a string across faces of both jambs and position face of mullion in line with jamb faces. Mark location of mullion on floor.
10. Loosen sidelight jamb with compression anchor and push jamb back on wall.
11. Lift sill and secure mullion footclips to floor.
12. Lower sill to floor.
13. Tighten unsecured jamb against sill using compression anchor. Square and plumb jamb. Secure jamb in place with base anchor screws.

For more information and an installation video go to www.curries.com

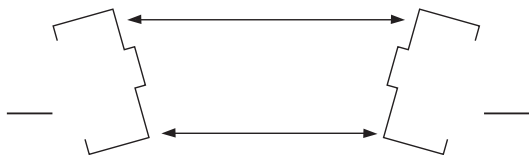
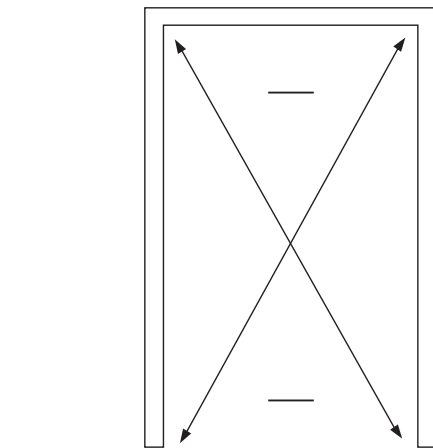
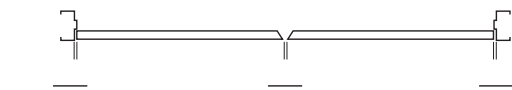
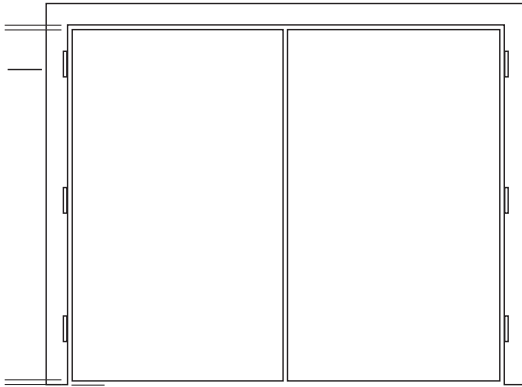

DOORS

CLEARANCES

- _____ Top
 - _____ Bottom
 - _____ Hinge Edge
 - _____ Lock Edge
- NOTE:** Measure entire edge
- NOTE:** Measure entire edge

DOOR PANEL FLATNESS

- _____ Hinge Edge
- _____ Lock Edge

DOOR PANEL SIZE

- _____ Height
 - _____ Width
 - _____ Square
- NOTE:** Measure diagonally

DOOR PLANE

- _____ Pairs only
- NOTE:** Door closed, edges meet flush

FRAMES

DIMENSIONS

- _____ Opening Width Top
- _____ Opening Width Center
- _____ Opening Width Bottom
- _____ Opening Height & Centered (Pairs)
- _____ Opening Height Hinge
- _____ Opening Height Lock

HARDWARE LOCATIONS

- _____ Lock
- _____ Strike
- _____ Hinges
- _____ Backset-Strike

SQUARE

- _____ **NOTE:** Measure diagonally

PLUMB OF JAMB

- _____ Active
- _____ Inactive

JAMB TWIST

- _____

Systematically Analyze

The most frequent cause of poor door and frame fitting is improperly assembled or inadequately installed frames. Since most complaints received are not explicit as to the actual cause of the problem, but rather the results of the problem, it becomes necessary to analyze the situations systematically to determine the best course of action.

Proper inspection of an installation requires the use of certain tools which will facilitate consistent accurate measurement for best results. The following list includes the minimum basic equipment which will be needed:

Basic Equipment List

1. Steel Tape: Measure doors and frame openings and diagonals as a double check for squareness.
2. Framing Square: Determine squareness of frame and double check for jamb twist.
3. Solid Steel Rule: 4 ft. - Check for jamb twist in single door frames.
4. 6 ft. Masonry Level: Determine level of head, plumb of jambs and to check for bow in doors.
5. Plumb Bob and Line: Double check plumb of jambs.

Experience with troubleshooting and correcting door/frame installation problems will undoubtedly lead to other methods and devices to help make the job easier.

Too Tight a Fit

Regardless of the type of complaint, it will be advantageous to obtain all the data possible that can reveal any indication of improper installation or distorted door or frame parts. In the case of drywall frames make sure the frame fits the wall section without spreading the throat or without undue clearance. Too tight a fit can cause distortion and dislocation of the rabbets which in turn can decrease available door to frame clearance on the lock edge. Also this will cause poor fitting miter joints in knockdown or KD frames.

Masonry Alignment

Masonry frames are normally installed and anchored to the concrete floor before the wall is built. They are then anchored to the wall between courses and often filled with mortar. It is obvious that initial alignment of a masonry frame is critical and that sufficient support must be given to prevent distortion due to the accumulated weight of wet mortar. If a spacer is not placed in the opening between the jambs at the mid-point, as well as at the floor during this process there will likely be a degree of bow and possible twist in the jambs. This will, in the very least, decrease available door to frame clearance.

Table 1

Table 1, on pages 10 and 11, is a guide that can be followed to collect pertinent data necessary to analyze an installation problem.

Following Table 1 are recommended corrections for doors suspected of being twisted or bowed (see pages 12 and 13).

Table 1

Single Door Frames

1. With doors closed, measure clearances at head and both jambs.
Head 1/8"
Jamb 3/32"
Undercut (1-3/4" Door) 5/8"
Undercut (1-3/8" Door) 3/4"
2. With door closed, observe whether door rests flush on stops of jamb and head.
3. With door ajar, observe whether door will remain stationary or swing open or close involuntarily.
4. With door open, place framing square in corner against jamb and head rabbets to determine squareness of both jambs with head. Measure opening width at head and at floor.
5. Measure with steel tape diagonally from corner to corner of opening in both directions and on both sides of frame.
6. Check head for level.
7. Determine plumb of both jambs using the 6 ft. level vertically on the jamb faces or by suspending a plumb bob on a line against the head face and adjacent to each jamb.
8. Check for jamb twist by laying the framing square flat on the floor against the rabbet or face and mark a line on the floor toward the opposite jamb. Repeat for both jambs. **NOTE: A 4 ft. steel ruler simultaneously placed against the faces of opposite jambs will verify results.**

Pair of Doors and Frames

1. With doors closed, measure clearances at head, both jambs, and between doors.
Head 1/8"
Jamb 3/32"
Center 3/16" (1/8" with "Z" astragal)
Intermediate Mullion 3/32"
Undercut (1-3/4" Door) 5/8"
Undercut (1-3/8" Door) 3/4"
2. With doors closed, observe whether they are flush with each other at meeting edges or with stops of intermediate mullion.
3. With doors ajar, observe whether they will remain stationary or swing open or close involuntarily.
4. With doors open, place framing square in corner against jamb and head rabbets to determine squareness of both jambs and intermediate mullion (if used) with head. Measure opening width at head and floor.
5. Measure with steel tape diagonally from corner to corner of opening in both direction and on both sides of frame. On frames with intermediate mullions do this for both door openings plus over the full frame opening.
6. Determine plumb of both jambs and intermediate mullion (if applicable) using the 6 ft. level vertically on the jamb or mullion faces or by suspending a plumb bob on a line against the head face and adjacent to each jamb or mullion.

Pair of Doors and Frames (continued)

7. Check for jamb twist by laying the framing square flat on floor against the rabbet or face and mark a line on the floor toward the opposite jamb. Repeat for both jambs and both sides of the intermediate mullion if applicable.

Remarks

1. Inconsistent clearances on a given side indicate likely out of square frames or twisted jambs or improperly seated hinges or reinforcements.
2. Incomplete contact with stop for single doors or uneven meeting edges for pairs of doors indicate out of plumb or twisted jambs or both.
3. Involuntary movement of doors indicate out of plumb or twisted jambs or both.
4. Out of square jambs and heads will cause inconsistent clearances or interference between door and jamb or head or between meeting edges of pairs of doors.
5. If diagonal measurements are identical the frame opening is square. This procedure can confirm indications observed per step 4.
6. Check head for level.
7. Evaluation of plumb should be done in conjunction with evaluation for twist because the latter can affect the plumb indication, depending upon the degree of twist. Both jambs should give precisely identical readings on a level bubble. If there is any question, confirm the reading using a plumb bob.
8. The extended lines should meet as one straight line if both jambs are in plumb and without twist or they should be parallel if there is no twist but some out of plumb.

Checking Doors Suspected of Being Twisted or Bowed

Single doors which do not fit flush against the stop of the strike jamb or pairs of doors which are not flush at the meeting edges could contain twist or bow. This can be determined with the door in its hung position by placing a 6 ft. level vertically against the face of the door adjacent to the lock edge. Any bow or twist in the door will be evident if the level will not lie flat against the door over its entire length. It is important that a minimum 6 ft. level be used to adequately indicate bow or twist.

If no deformation of the door is indicated, check the plumb of the lock edge with the door in its closed position. If it will not latch, hold it without forcing it against the frame stop. Compare the plumb of the door with the plumb of the hinge and strike jambs for single doors, or with both hinge jambs for pairs of doors. If the plumb of the door edge is identical with the hinge jamb, even though they may not be vertical, this would confirm that no twist or bow exists. Further, if the hinge and/or strike jamb are out of plumb this would confirm the cause of the door not fitting properly.

Methods to correct door and frame fitting problems are on page 12 and 13.

ASSA ABLOY, the global leader
 in door opening solutions

CLEARANCES

KD drywall frames can usually be corrected for minor distortions or misalignment by releasing compression anchors or detaching stud anchors and readjusting. Masonry frames which have been grouted or filled with mortar are virtually impossible to correct. If distortions or

mis-alignments are minor enough, clearances can be balanced somewhat by shimming the appropriate hinges. See instructions for clearance adjustments beginning on page 3.

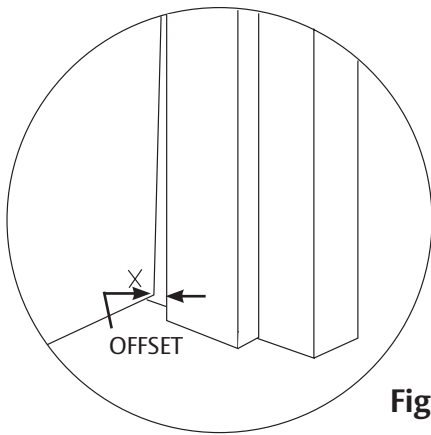

Figure 1

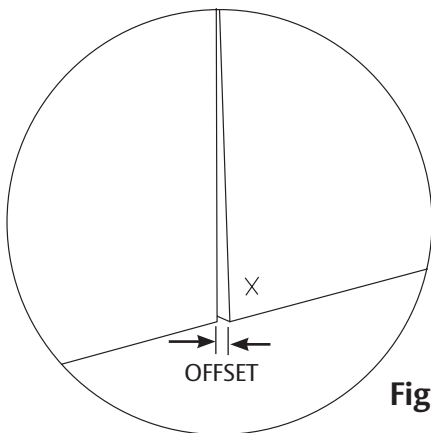

Figure 2

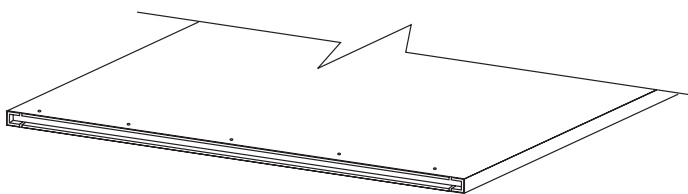

Figure 3

Door Modification to Correct Out of Plumb Jamb

Figure 1 & 2

Single doors which do not lie flat against the frame stops, or pairs of doors which do not fit flush with each other at the meeting edges due to jambs being out of plumb can be modified by creating a twist to conform to the error in the frame.

1. Measure the distance that the inside corner of the door is offset from the stop, or in the case of pairs of doors, the distance that the door in question is offset from the other at the corner of the meeting edge.
2. Drill out the spot welds attaching the end channel on the outside (side away from the frame) on the end which is offset from the frame stop or from the meeting edge of the opposite door of a pair.

Figure 3

Do Not Drill Through the Flange of the End Channel.

Make sure all welds are released.

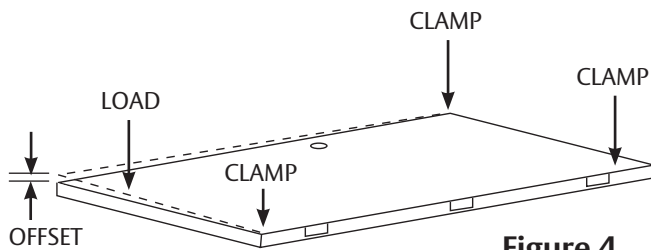

Figure 4

Door Modification to Correct Out of Plumb Jambs (cont.)

Figure 4

3. Lay the door flat, outside up on supports at the three other corners and clamp them in position. Force the remaining corner down a little more than the amount of offset measured and clamp the released end channel flange to the face skin using several #7R vise grip clamps.

Remove the load and determine if sufficient twist is retained. Re-load and re-clamp as necessary to get the proper offset.

4. When the proper offset is achieved plug weld through the drilled holes to secure the end channel flange to the face skin.

Grind the weld, fill, finish smooth and re-paint as necessary.

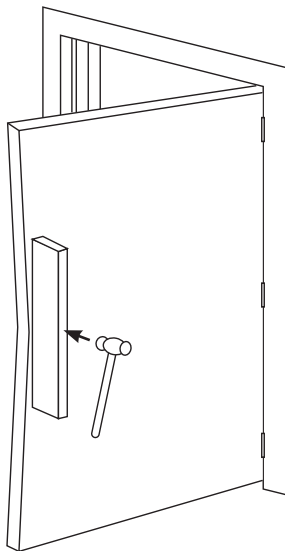

Figure 1

Straightening of Bowed or Twisted Doors (Distorted Lock Rail)

Figure 1

1. With the door in its hung position, determine the center of bow or location of lock rail distortion. Place a minimum 2 ft. long 2 x 4 block of wood on edge adjacent to the lock rail edge centered over the center of the deformation.
2. Strike the center of the block sharply with a hammer re-checking flatness with 6 ft. level after each blow.

NOTE: For best results, remove lockset and latch bolt.

Figure 2

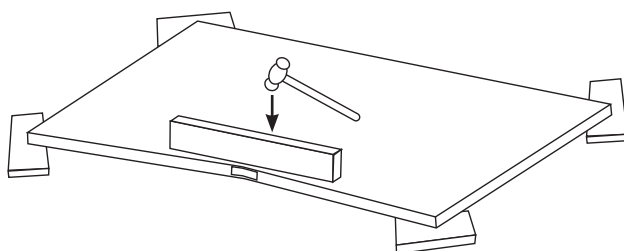

Figure 2

3. If the preceding method does not correct the problem, remove the door and lay it flat on 2 x 4 wood supports at the corners as shown in Figure 2, and repeat Figure 1/Step 2 as stated above.

NOTE: Use caution when straightening doors with large edge cut-outs (example: mortise lock cut-outs) to prevent permanent deformation of the door face skin in that area.



ASSA ABLOY

ASSA ABLOY, the global leader
in door opening solutions

INSTALLATION AND TROUBLESHOOTING

June, 2014

INSTALLATION AND TROUBLESHOOTING

June, 2014

 **CURRIES**[®]

 **ASSA ABLOY**

ASSA ABLOY, the global leader
in door opening solutions



ASSA ABLOY

ASSA ABLOY, the global leader
in door opening solutions

INSTALLATION AND TROUBLESHOOTING

June, 2014



ASSA ABLOY is the global leader in door opening solutions, dedicated to satisfying end-user needs for security, safety and convenience

CURRIES • 1502 12th Street NW
Mason City • IA 50401
Phone: 641-423-1334
Fax: 641-424-8305
Website: www.curries.com

Copyright © 2014, AADG, Inc., an ASSA ABLOY Group company.
All rights reserved. Reproduction in whole or in part without the express written permission of AADG, Inc. is prohibited.

CUITM-0614